



Fitness element FP-009ST Rowing - turquoise

Product type FP-009ST-10

Basic information

Age category	from 15 years
Minimum area	4,07 m x 3,8 m
Equipment measurements	1,07 m x 0,8 m x 0,9 m
Free fall height:	1.0 m
Load capacity:	120 kg
Max. number of users:	1
Fall zone: EN 1177	null
Designation:	exterior
Availability of spare parts:	supplied by the
Certificate of Compliance:	ČSN EN 16630:2016

Material

Supporting column, handles - made of steel tubes
Seat and backrest - HDPE

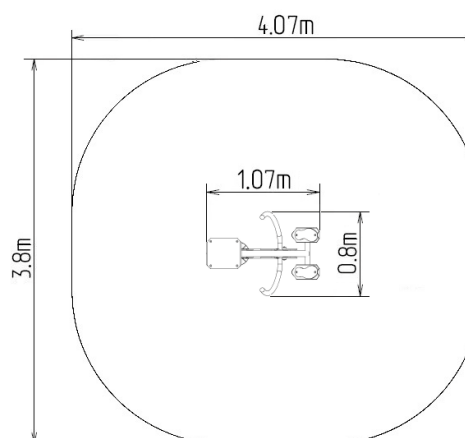

Finish

Duplex powder coated with coat curing
Hot-dip galvanizing

Description

Seat and backrest are made of aluminum and covered with HDPE polyethylene (high-pressure, full-colored polyethylene, which is characterized by high color stability, UV resistance). The handles are made of powder-coated steel tubes. The supporting column is made of a steel tube with a mounting flange at the bottom. The seat frame and tread are made of powder coated sheet metal. Rolling bearings are used for movable connections. Holes are sealed with steel elements at the ends. All fasteners are stainless.

Functions: It works out the upper part of the body, such as the biceps and muscles of the corset and the muscle groups of the lower extremities. It improves the performance of the heart and the respiratory tract and the cardiovascular functions.

Instructions: Sit down on the seat and grasp the handles. Draw the handles nearer and stretch your legs. Return back to the original position and repeat the exercise.